

# MBBR SYSTEMS

MOVING BED BIOFILM REACTOR

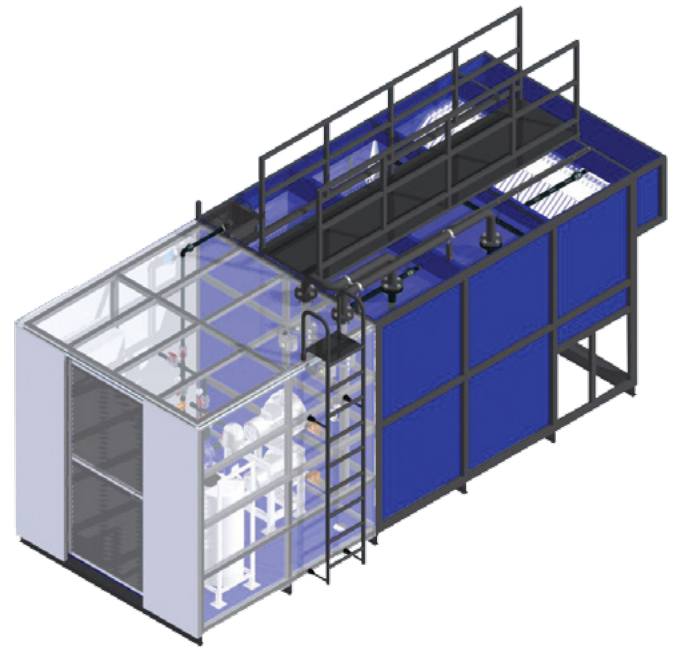

MOVING MEDIA



REACTOR TANK



DIFFUSER SYSTEM

## AQUALINE MBBR SYSTEMS

Aqualine MBBR systems can be used to treat wastewater from various sources (domestic, wineries, dairies etc.) in combination with other processes to achieve the appropriate treatment objectives: after anaerobic treatment for polishing BOD load; before activated sludge for high BOD/ COD treatment, for upgrading - converting of existing plants (lagoons, oxidation ponds and activated sludge plants) or as post treatment to existing activated sludge for nitrogen removal to comply w/new regulation limits.

Aqualine MBBR systems include the small carrier elements, which are less dense than water (0.93 - 0.95 SG), provide a large protected surface for bacteria culture and allow sites to retain active biomass within the bioreactor. Also due to the unique design of the biofilm carriers, the bacterial cultures are protected from operating excursions (pH, temperature, and toxic shocks) to yield a very robust system with variable load fluctuations.

Aqualine MBBR systems are applicable to wide range wastewater flows; from 20 m<sup>3</sup>/day to 10.000 m<sup>3</sup>/day.

### MORE INFO

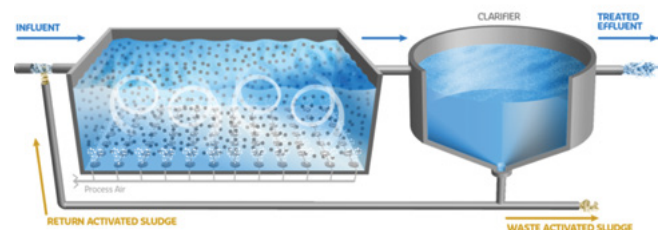

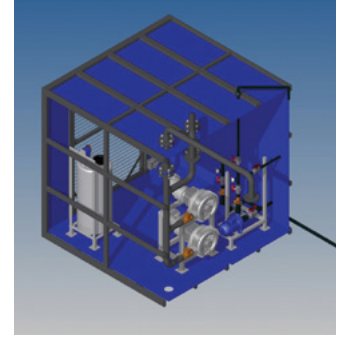
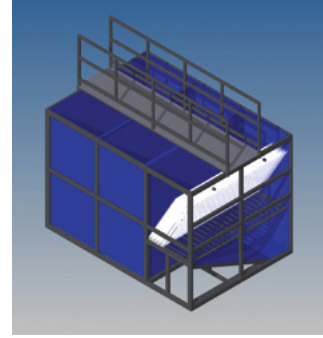
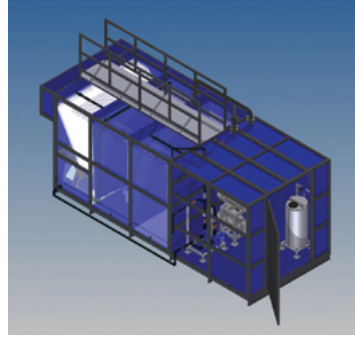
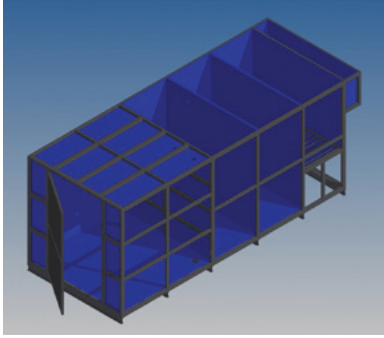

## DESIGN CONSIDERATIONS

- Requires primary treatment, FOG <100 mg/l
- Treatment design & configuration is arranged according to inlet & outlet parameters, including WW temp.
- Organic and hydraulic loading is variable, dependent on influent parameters and effluent requirements.
- Standard MBBR maximum media fill fraction in the reactor= 70 %
- Media retention screen(s) keeps media in tank

## FEATURES AND ADVANTAGES

- Self-regulating biomass.
- Flexible design that allows for capacity increment.
- No operational adjustments, only equipment maintenance.
- Stable under large load variations.
- Smaller foot prints.
- Low investment cost.
- Single-pass treatment.
- Multiple applications.
- Extremely compact and simple biological treatment system.

## INSTALLATION LIST

- Domestic/Resort
- Food Processing
- Landfill Leachate
- Marine
- Meat Processing
- Mining
- Petrochemical
- Pharmaceuticals
- Power Plant
- Pulp & Paper
- Vehicle Wash

PARAMETER	OXIDATION POND	EXTENDED AERATION	SBR	MBR	ANAEROIC / AEROBIC	MBBR
Area	High	High	Medium	Low	Medium	Low
Buffer Zone	High	High	Medium	Low	Medium	Low
Capital Cost	Low	Low	Medium	High	Medium	Low
O & M Cost	Low	High	Medium	Medium	Medium	Low
Replacement Cost	Low	Medium	Medium	High	Medium	Low
Operational Ease	Low	Low	High	High	High	Low